

A JOURNEY OF DISCOVERY

'From the minute one enters the studio of Overgaard & Dyrman, there is an immediate sense that this is no ordinary design office. The space feels like something out of the opening chapter of a Jules Verne novel: rows of hand-drawn sketches hang suspended from the ceiling, an entire wall is covered with leather and metalworking tools, and the air is rich with the smell of newly cut and oiled leather. In the center of it all, an Overgaard & Dyrman Wire Dining Chair - the firm's iconic

first design - has been fully deconstructed and laid out on display, like some prized archaeological find.

The whimsical ambience of this strange and stylish studio is neither accidental nor artificial. Instead, it is a reflection of Jasper Overgaard and Christian Dyrman's highly curious, hands-on approach to their work and a nod to the journey of discovery that they have been on for a decade and a half.'

Text written by Austin Sailsbury,
originally published in "Northern Comfort",
by gestalten, Berlin, in 2018

Photography: Søren Larsen
Jasper Overgaard

Text: Austin Sailsbury

Second edition: Sep. 2021

All rights reserved

OVERGAARD & DYRMAN
www.OandD.dk

ABOUT O&D	4	-	THE O&D STUDIO	9	-	WORKSHOP & PRODUCTION	27	-	THE CIRCLE DINING CHAIR	35	-	THE WIRE COLLECTION	63
HIGHLIGHTED PROJECTS	91	-	Jewel Box	93	-	Jogailos Residence	101	-	Private Residence	107	-	E. Ketov Apartment	115
Hotel Amerikalinjen	119	-	Coconut Grove Residence	125	-	Ersted House	129	-	Restaurant Hjemme	135	-	Catskill Cottage	139
		-	Kosta Browne Winery	143	-	Private Home	149	-	COLLECTION OVERVIEW	155	-		

About O&D

FOUNDED ON FRIENDSHIP, GUIDED BY CURIOSITY

After meeting at Aalborg University in 2005, Christian Dyrman and I found that our individual creative strengths complemented each other well, and so we began working on several student design projects together. During this period, we learned that we are both highly dedicated and extremely stubborn when it comes to both design and craftsmanship. Those years working together as engineering students laid the foundation for what would later become Overgaard & Dyrman (O&D), the design studio we formed together in 2013.

Over the past 16 years, Chris and I have developed a close friendship and a successful creative partnership based on trust and shared values. We have learned which aspects of design, production, and business best suit each of our personalities. And, although we were both trained in architecture and design, each of us also brings a unique set of specialty skills to O&D. Whereas Chris is a skilled black-

smith, I am a self-taught leathersmith. And it is these two particular skills that helped us to develop and refine our first O&D product, the Wire Dining Chair, which was launched at IMM Cologne in 2014.

The idea for the Wire Dining Chair—and later the entire Wire Collection—originated when we were students. Working together, Chris and I had conceived the chair as a synthesis of two distinct and time-honored crafts: saddle-making and precision metalwork. At one point, two established Danish design brands showed interest in producing our Wire Dining Chair. But, after being disappointed by the prototypes that came back from Asia, we realized that in order to achieve the quality we wanted, we were going to have to produce the chair ourselves, right here in Denmark.

At the time, we both had good, full-time jobs and had no ambitions to start our own design studio. But the more time and energy we in-

vested in that first chair, the more we believed in the concept and in each other.

Then, one day in 2013, we decided we had to go all in. We quit our jobs and promised each other we would give the project everything we had for one year. Over the next twelve months, we poured our blood, sweat, and tears into the process of perfecting the design of the first Wire Chair which during that process became a collection. As we continued refining our collaborative methods, we borrowed, bought, and built all the tools and fixtures needed to make the first Wire Collection pieces the right way.

In the end, it took us a year and a half before the first chairs were introduced into the market. We made the first 300 Wire Collection pieces ourselves: Christian did all the metalwork in an old hen house behind his sister's home, and I did all the leatherwork at my parent's place, where I converted my child-

hood bedroom into a makeshift workshop. Since 2014, we have added several new designs to the O&D collection. And though we have long since moved “out of the hen house,” and into a fully modern workshop in northern Denmark, Chris and I still work side by side, collaborating and challenging each other every day, pushing one another to reach for better, more innovative designs and the highest quality materials and craftsmanship.

Today, with the help of a passionate and highly skilled team of craftsmen and women in the O&D workshop, Chris and I continue to pursue the goal we first dreamed up when we were university students: to design and produce beautiful objects of the highest quality, meaningful objects that will both inspire and delight for generations to come.

Jasper Overgaard
Co-founder of Overgaard & Dyrman



The O&D Studio

EMBRACING EVERY STEP OF THE PROCESS

The Overgaard & Dyrman studio exists as a collaborative platform for creating original and meaningful furniture and lifestyle objects crafted with precision from the highest quality materials.

For us, the creative process is everything. From the first hand-drawn sketches to the final technical drawings, from the first prototypes to the first customer-ready product, it is our belief that only by embracing every step of this process of discovery and experimentation can we create uncompromising and original works.

With all of our designs, we want to honour the beautiful characteristics of the natural materials we work with. Through each of our creative processes, we work to celebrate those qualities—not hide them—and our goal is always to achieve the right balance of originality, functionality, and sustainability that has come to define the objects we make.

And therefore, whenever we sign our names to each Overgaard & Dyrman product, we are not only signing off on the quality of each item that leaves our workshop, we are proudly celebrating the design process and our team's journey of discovery and creativity.



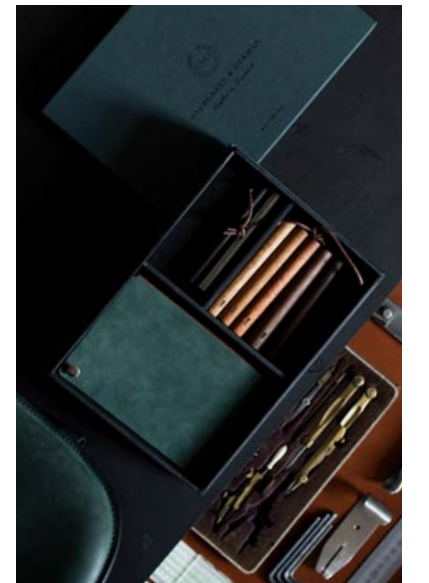
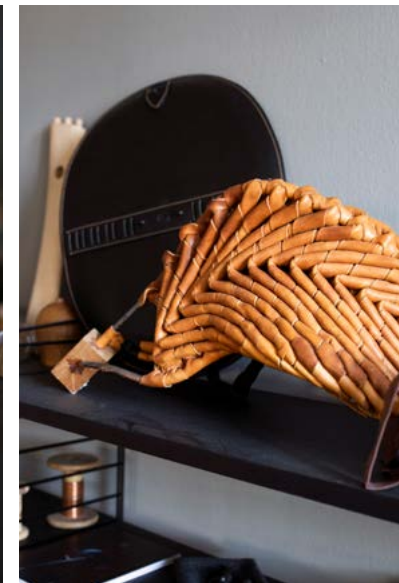

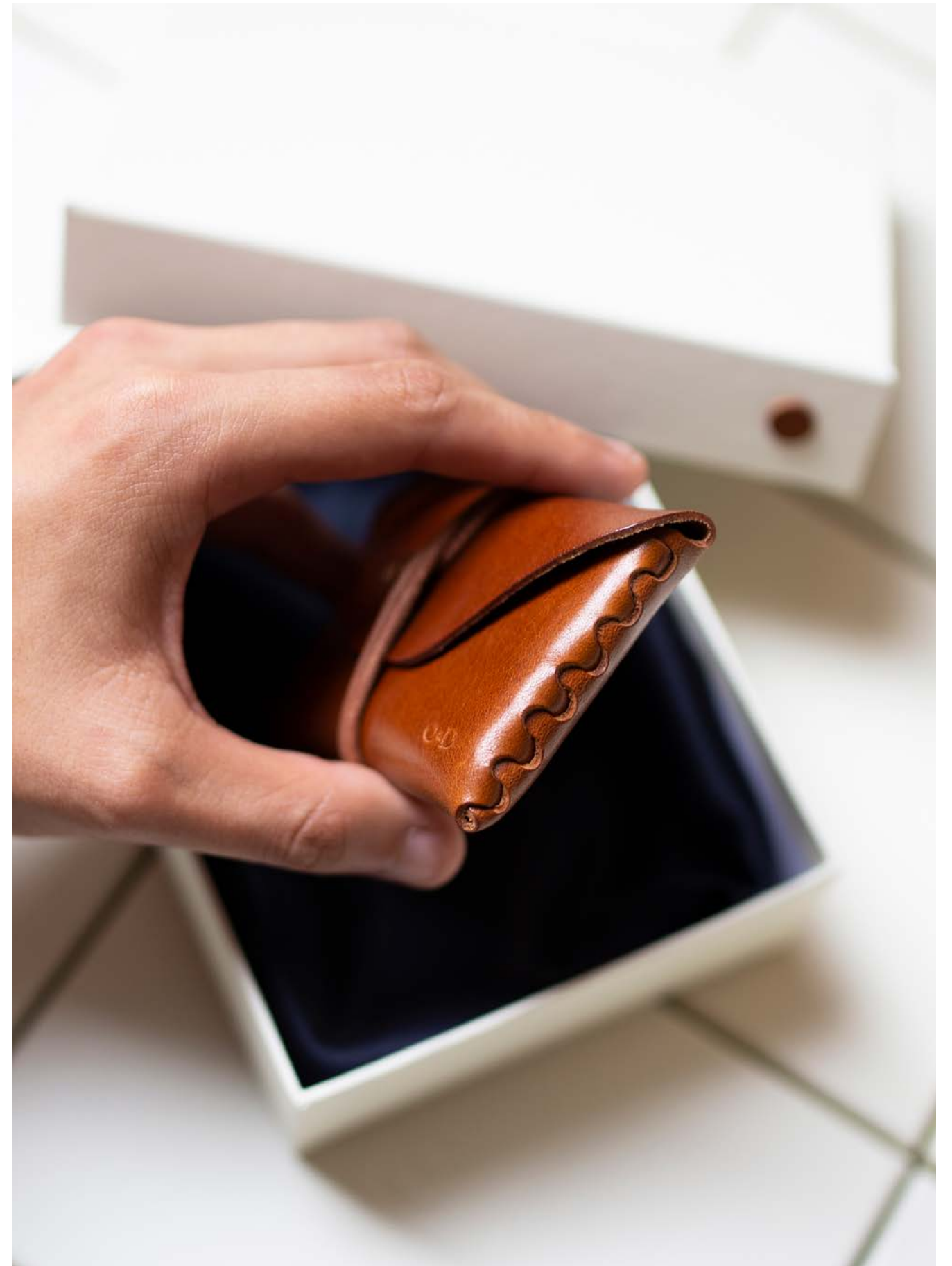

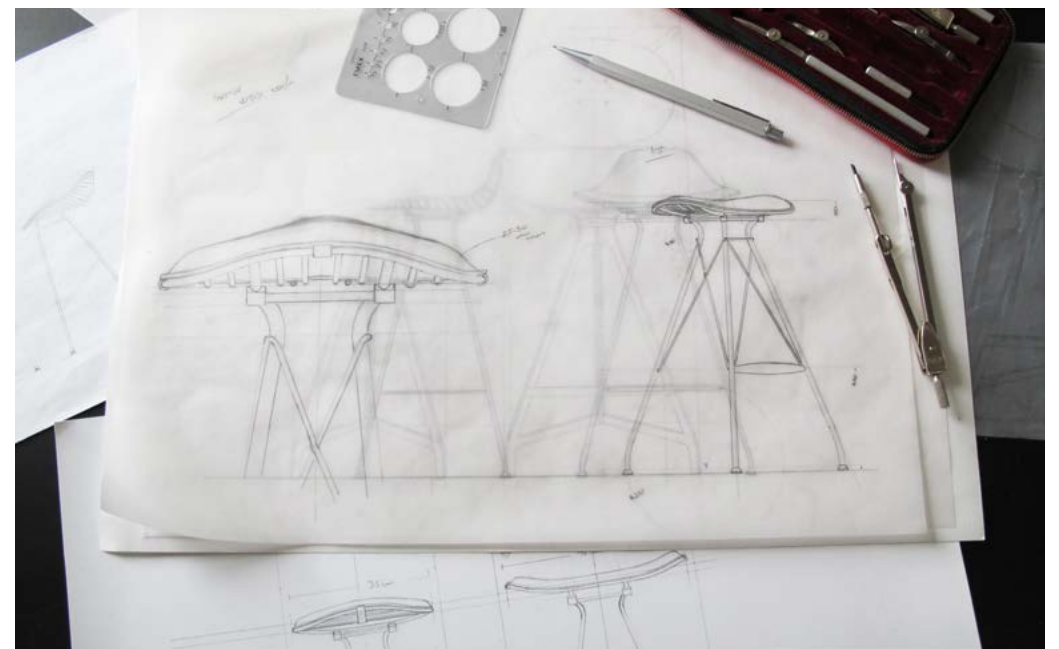
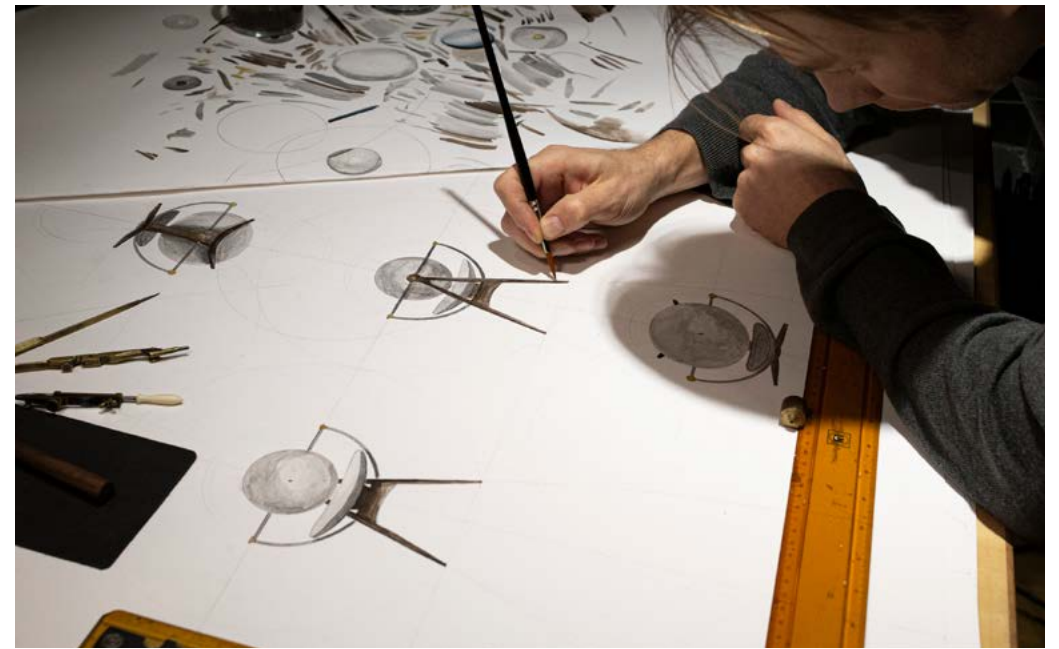
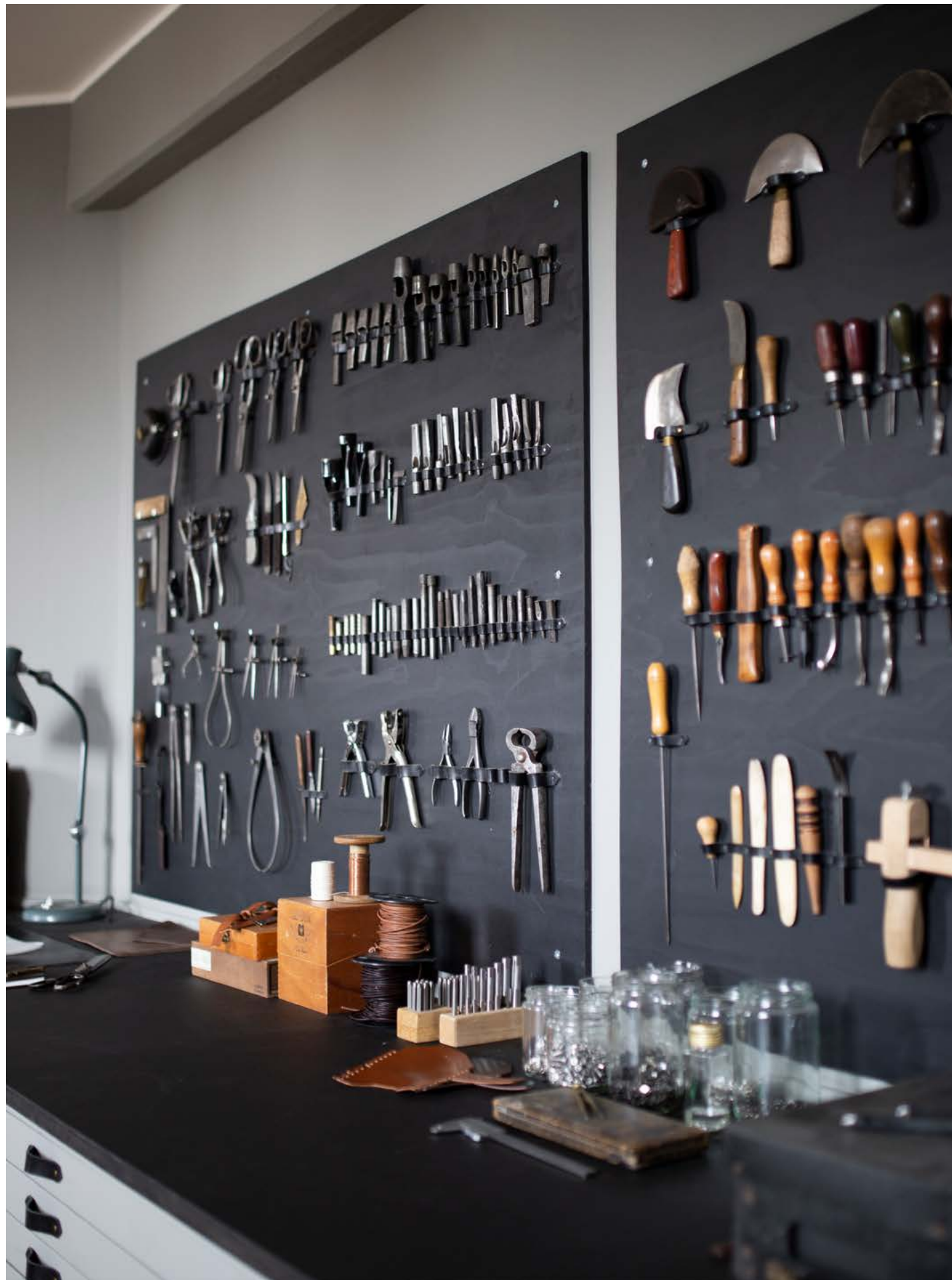

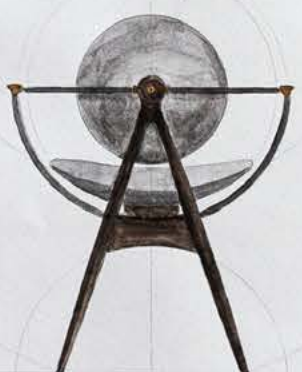

Charles Currier 116
Charles Currier
1850
10.2.1871







Workshop & Production

CREATED TO INSPIRE, CRAFTED TO LAST

By combining the highest quality materials with technical precision and an obsessive quest for originality, our work strives to connect our Scandinavian design heritage with an ongoing commitment to innovation and invention.

We want to make furniture and objects that are at once beautiful to look at, comfortable to use, and cleverly made. To do this, we work to get the best possible outcome with the techniques and knowledge accessible to us. Sometimes it is through traditional craftsmanship and sometimes with modern technology—most often, it is a combination of the two. By utilizing the best of both the old and new, we are actively preserving traditional skills while

also pushing the limits of what is possible with 21st-century tools.

At Overgaard & Dyrman, we have always felt that the best way to learn was by doing. So, with each new design we set out to learn each step of the process for ourselves. This way, we are always improving our production processes and developing a full understanding of all aspects of the products we create.

At the end of the day, the things we make are built to last for a really long time. Our hope is that every piece will have a good and useful life and will get passed on for generations.





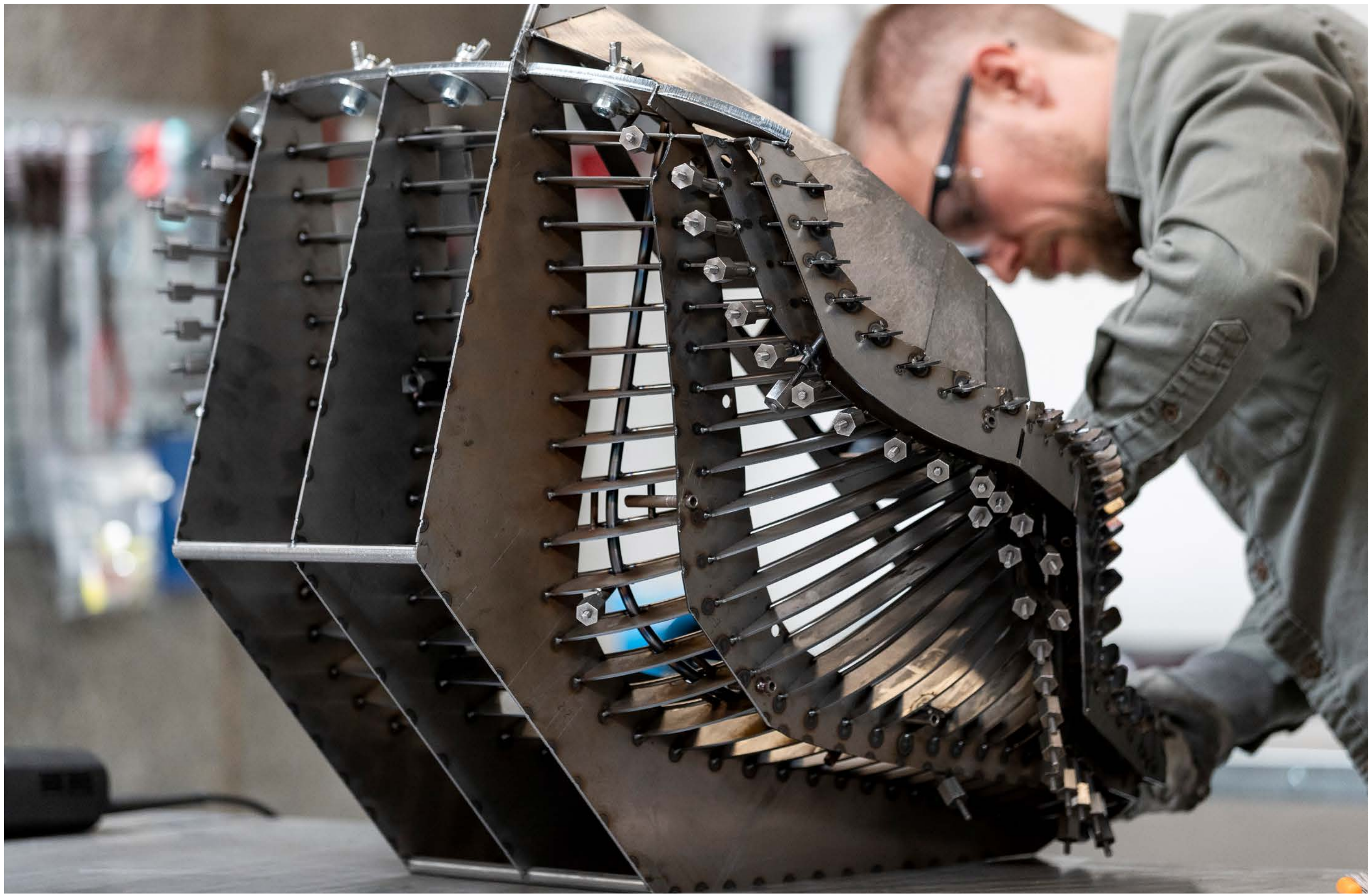

The Circle Dining Chair

GRACEFUL ARCS AND INVITING CURVES

From ancient mathematicians like Euclid, to Leonardo da Vinci, to Denmark's own Hans J. Wegner, the circle has always fascinated dreamers and makers. As a symbol of beauty and balance, the 'perfect geometry' of the circle has inspired the curiosity and creativity of architects and astronomers, philosophers and physicists. Continuing in this tradition, the inspiration for our Circle Chair, which was launched in 2019, was guided by the graceful arcs and inviting curves of the circle's elegant simplicity.

Because the Circle Chair has been designed as a practical object d'art, it is meant to be viewed and enjoyed from all sides, with each

angle offering a unique perspective on the ever-inspiring circle. Key design features of the chair include a trestle-shaped base inspired by the form of a drafting compass, contrasting materials used side by side, multiple customization options, and the choice of optional armrest.

Crafted with both new and traditional techniques, including CNC machinery and traditional wood joinery, the chair possesses a light and elegant expression.

Each Circle Chair is uniquely numbered and crafted in Denmark by skilled craftsmen and women.

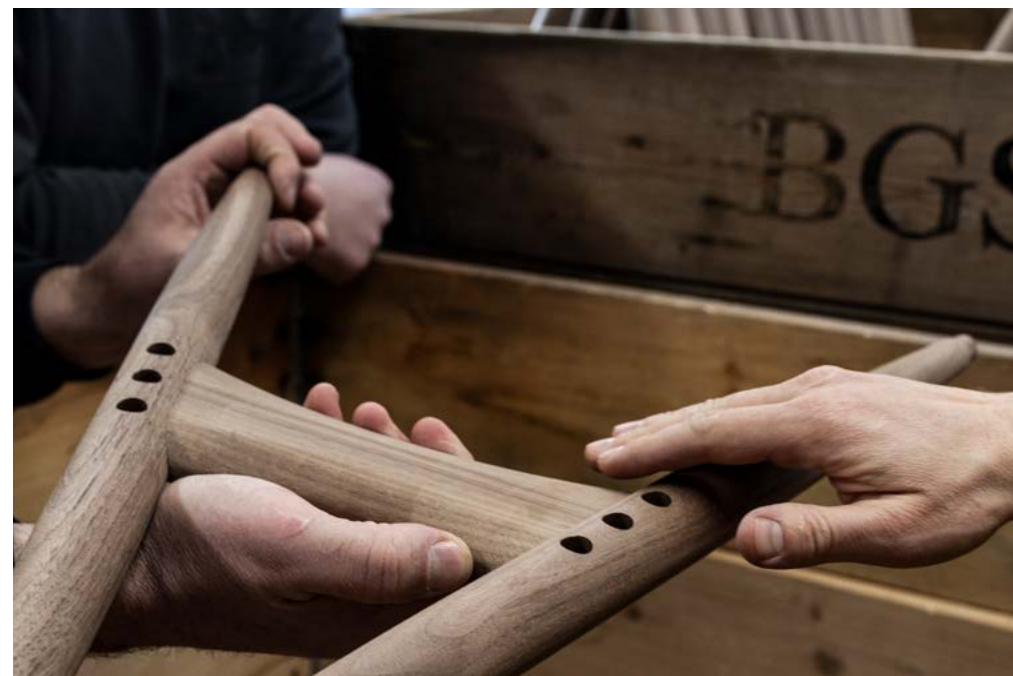



01 02



01
Circle Dining Chair brass badge
with unique number
02 / Opposite page
CDC without armrest - in black
stained ash, Coco fabric, Elegance
black leather and stainless steel





This page
CDC with armrest - in white
oiled ash, Artemidor boucle,
natural leather cord and brass



This page
Custom-made parts in solid
brass for a single Circle
Dining Chair with armrest

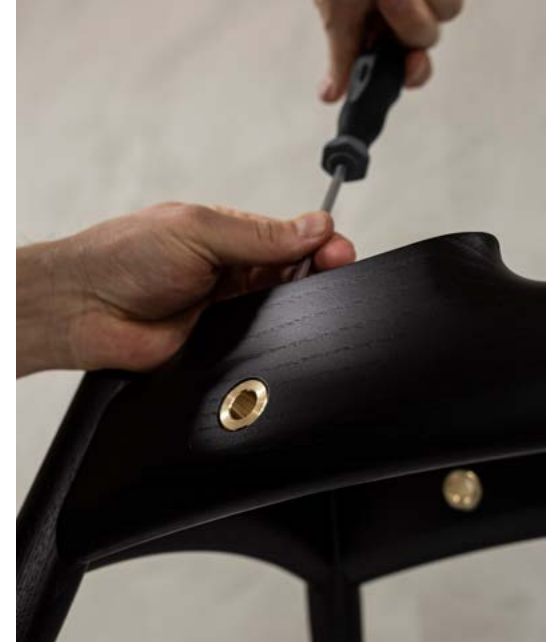



This page
CDC with armrest - in oak,
Matstone sand leather, natural
leather cord and brass

Opposite page
CDC without armrest - in
smoked oak, Maralinga fabric
and aged brass

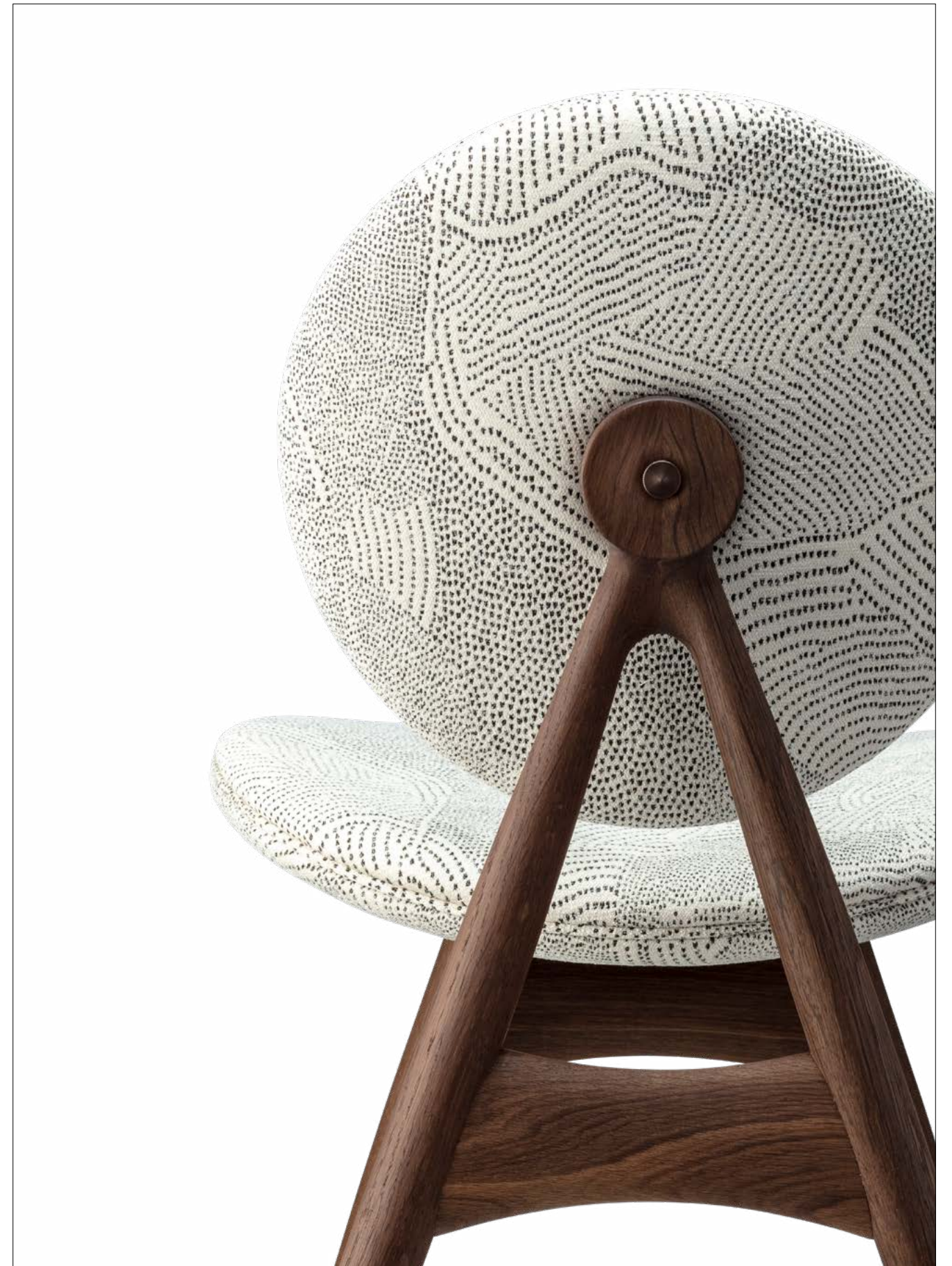



This spread
CDC's with and without armrest
- in smoked oak, Vienna Velvet,
Elegance dark brown leather
piping, dark brown leather cord
and aged brass

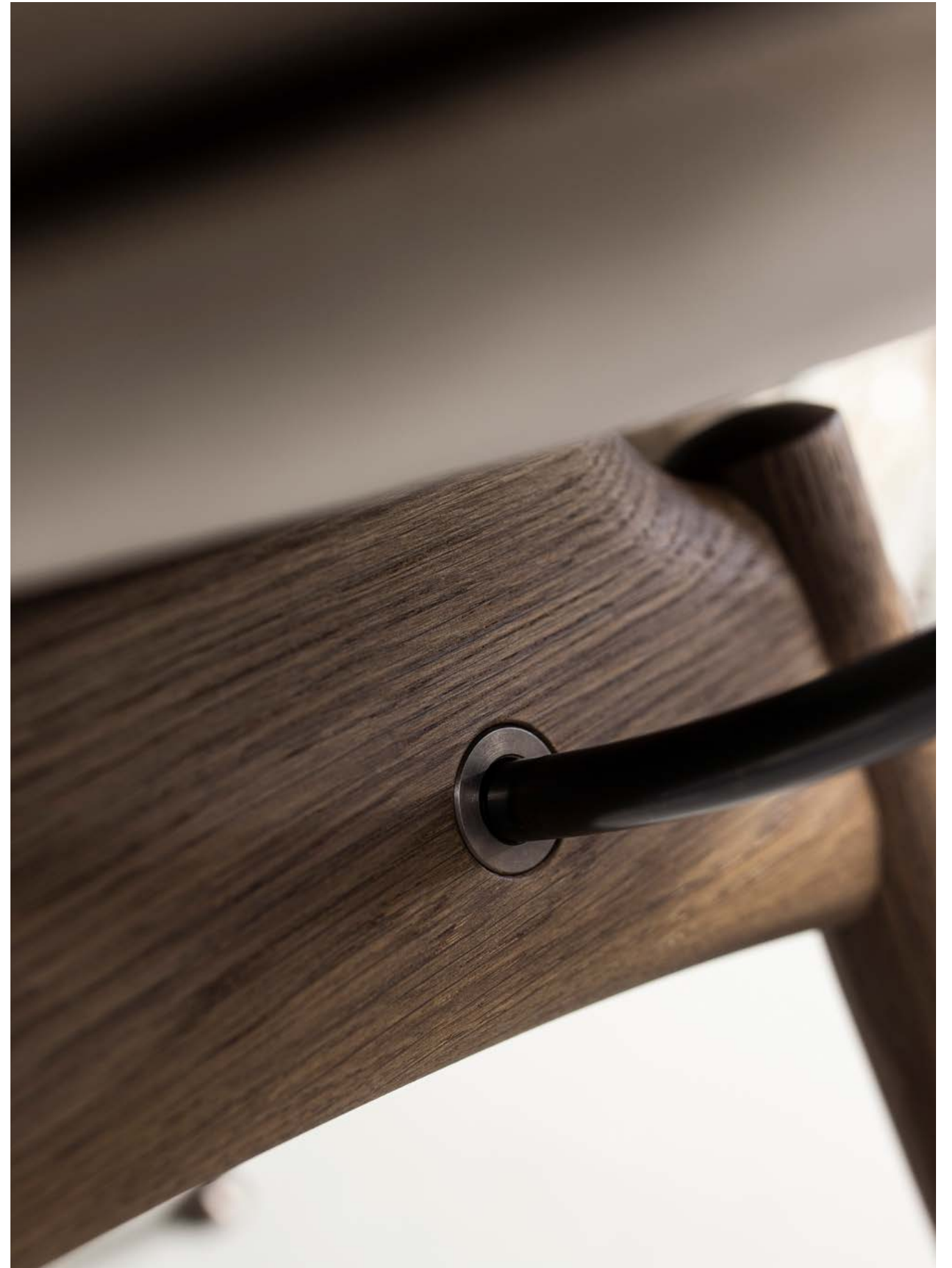

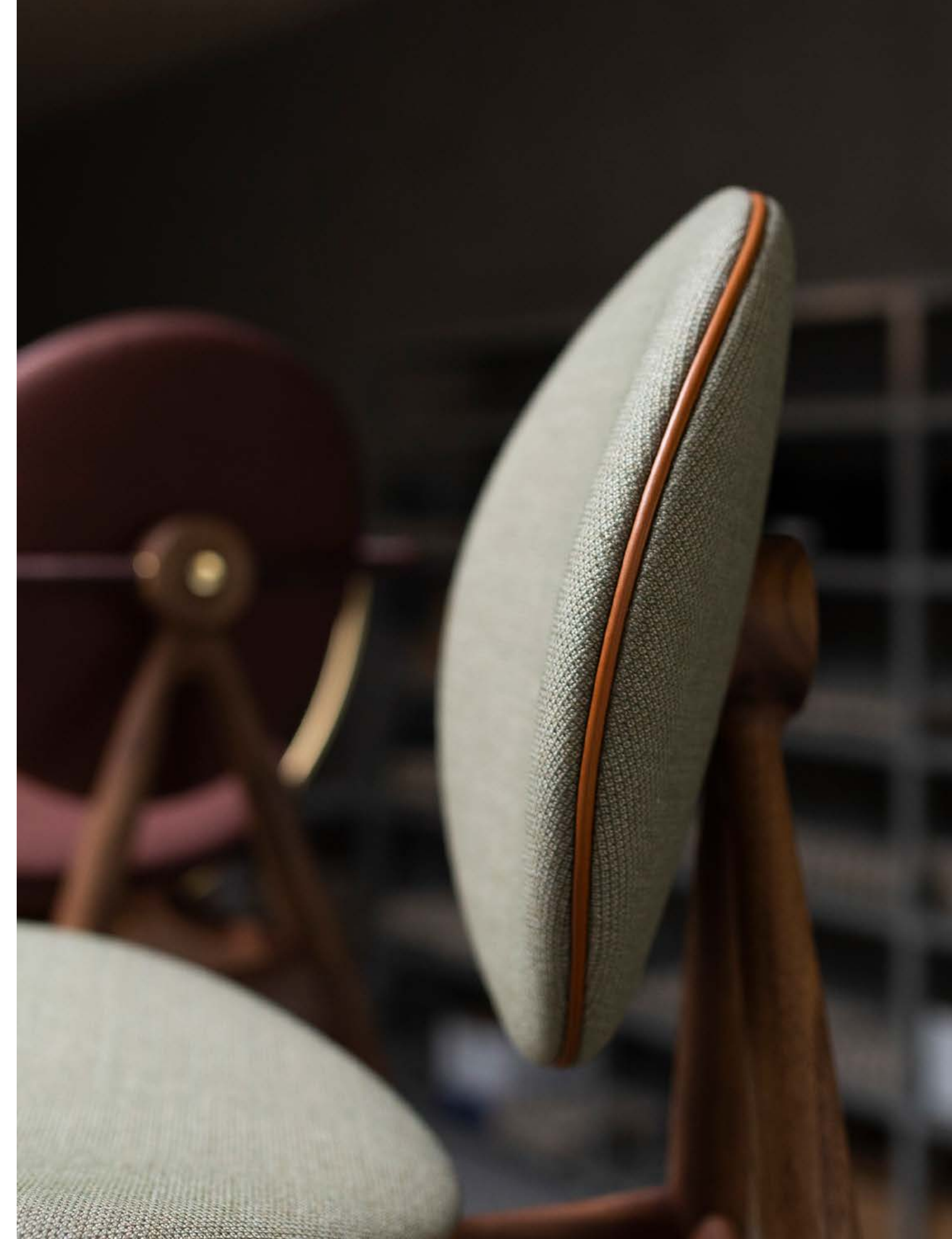
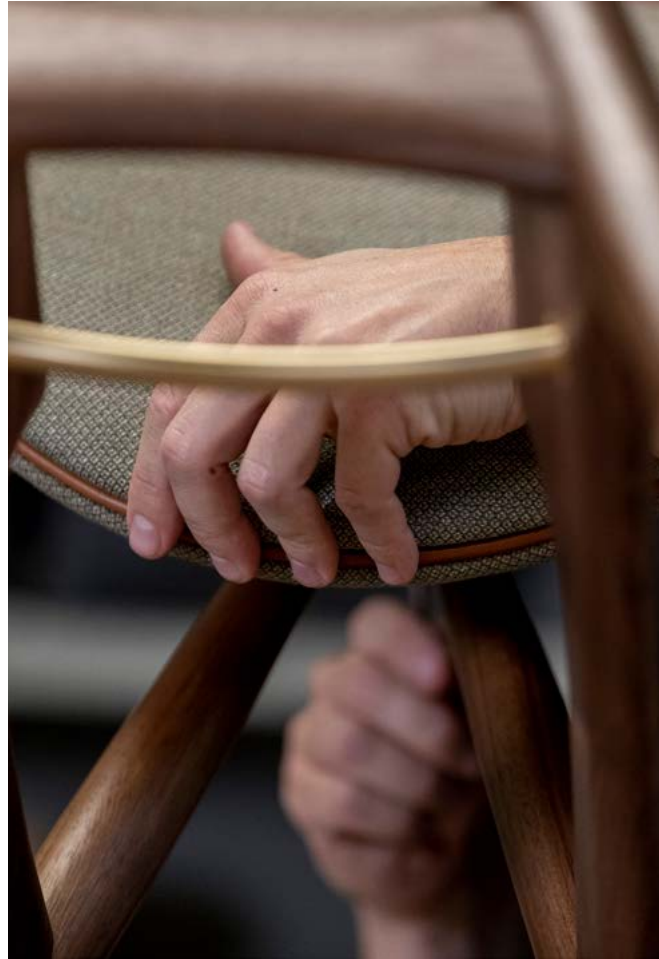

Opposite page
CDC without armrest - in
Fiord fabric and Elegance
whiskey leather piping



01 02

Opposite page
CDC with armrest - in
walnut, Fiord fabric, Elegance
whiskey leather piping, natural
leather cord and brass

01
Custom-made CDC foot with
ball joint and teflon glider

02
Fittings in brass, aged brass
and stainless steel



This page
CDC armrests covered in natural
and black leather cord

Opposite page
CDC with armrest - in walnut,
Elegance whiskey leather, natural
leather cord and brass



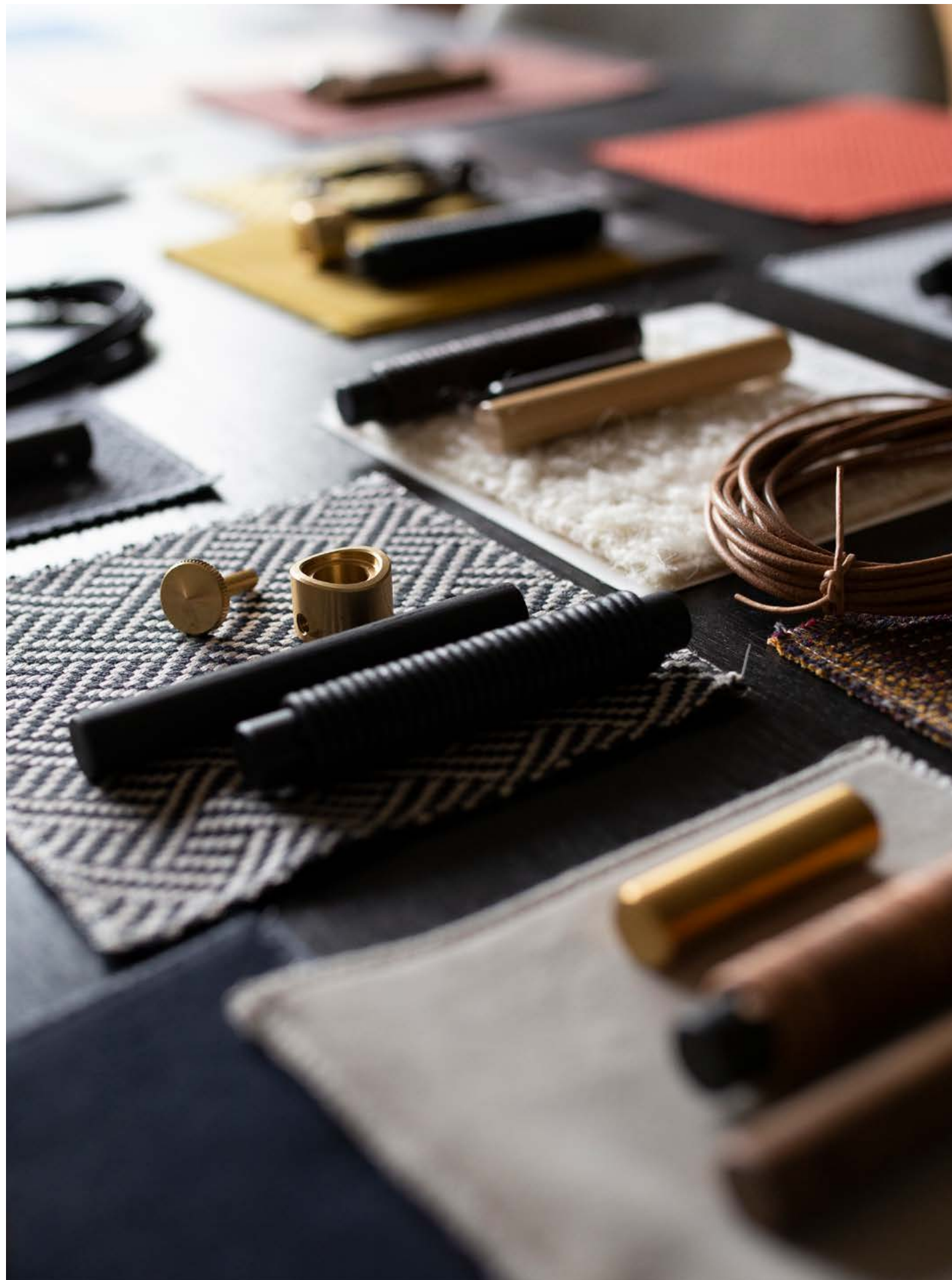

Previous spread

Left: Examples of CDC material options

Right: CDC with armrest - in COM fabrics, Elegance dark brown leather piping, dark brown leather cord and aged brass

This spread

Left: CDC without armrest - in smoked oak, Jaali fabric, Elegance dark brown leather piping and brass

Right: CDC with armrest - in black stained ash, Jaali fabric, Elegance black leather piping, black leather cord and stainless steel



The Wire Collection

PURSUING A VISION, STRIKING A BALANCE

Inspired by the dramatic aesthetic contrast between two very different materials—structural steel and premium quality, aniline-dyed leather—the Wire Collection combines two traditional forms of highly detailed, skilled craftsmanship: saddle-making and precision metalwork.

Each Wire Collection piece has been designed with an emphasis on aesthetic and structural balance. The result is an innovative collection of furniture that combines organic forms with timeless materials, everyday functionality, and ergonomic comfort.

Custom fixtures, jigs, and tools have been created by Overgaard & Dyrman to craft each individual piece of steel featured in the Wire

Collection. These custom tools, combined with modern CNC technology, and welding by hand allow us to bend, shape, and unite metal wires into highly detailed 3D forms. The result of this unique method of construction is a level of durability that satisfies the unique demands of this visionary furniture collection.

The Wire Collection includes six complementary design pieces: the Wire Dining Chair, the Wire Lounge Chair, the Wire Lounge Sofa, the Wire Coffee Table, the Wire Bar Stool, and the low Wire Stool.

All Wire Collection pieces are made-to-order by skilled craftsmen and women in Denmark. Each chair is individually stamped and numbered by hand.

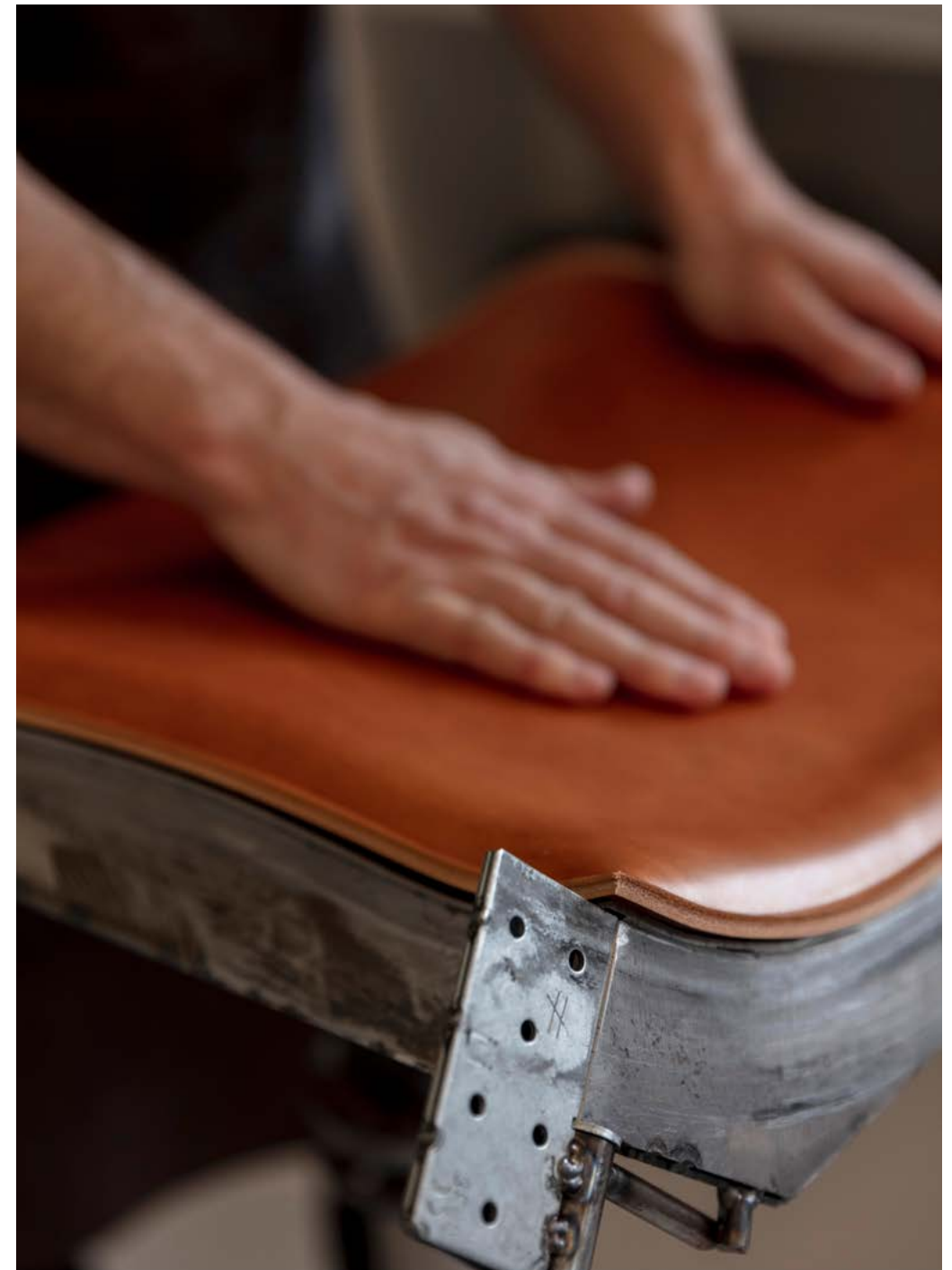







Opposite page
Wire Dining Chair - in dark brown
leather and matte black steel

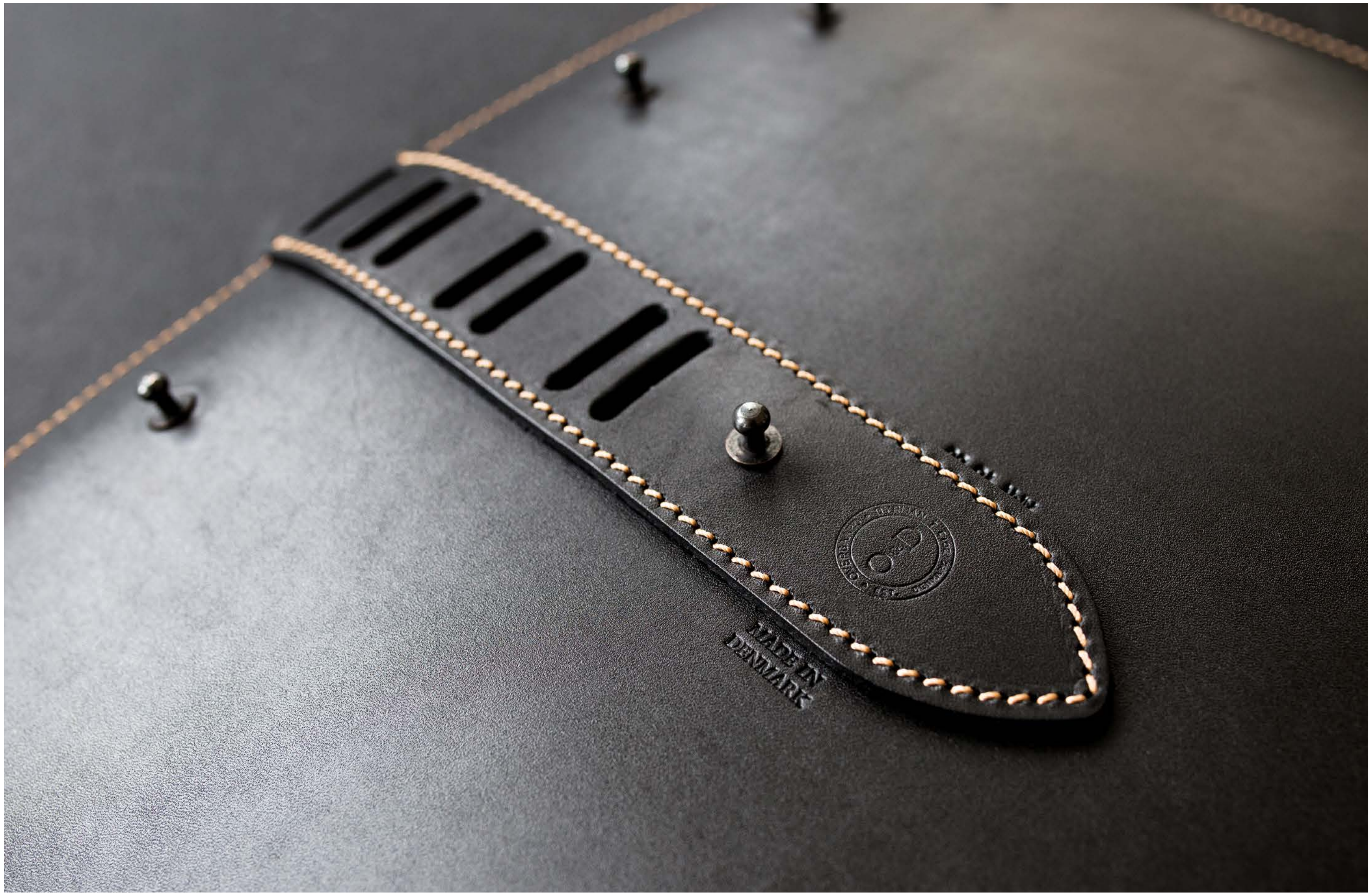

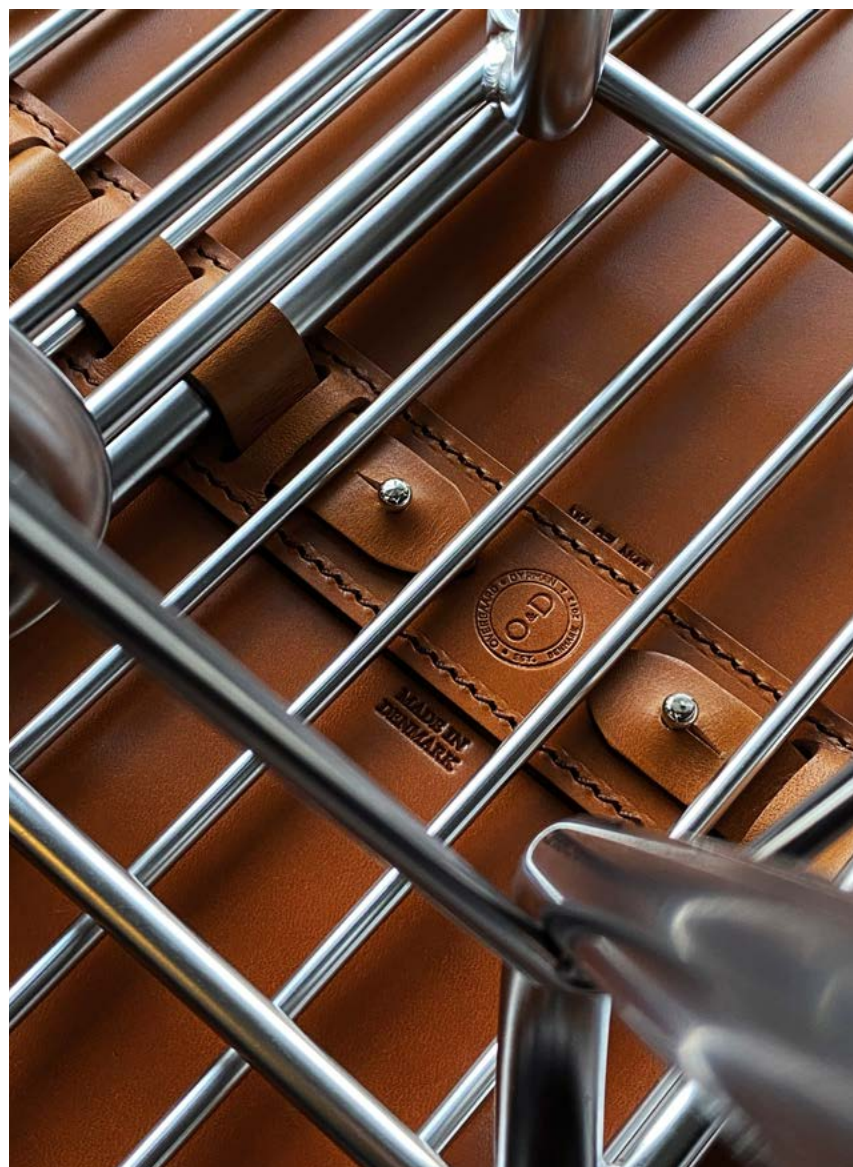

This spread
Left: Detail on Wire Bar Stool
- in whiskey leather and satin
chrome steel
Right: Wire Bar Stool (high) -
in Elegance black leather, oak
footrest and matte black steel

Next spread
Wire Bar Stool - in Two Tone
Matstone sand/black leather
and matte black steel

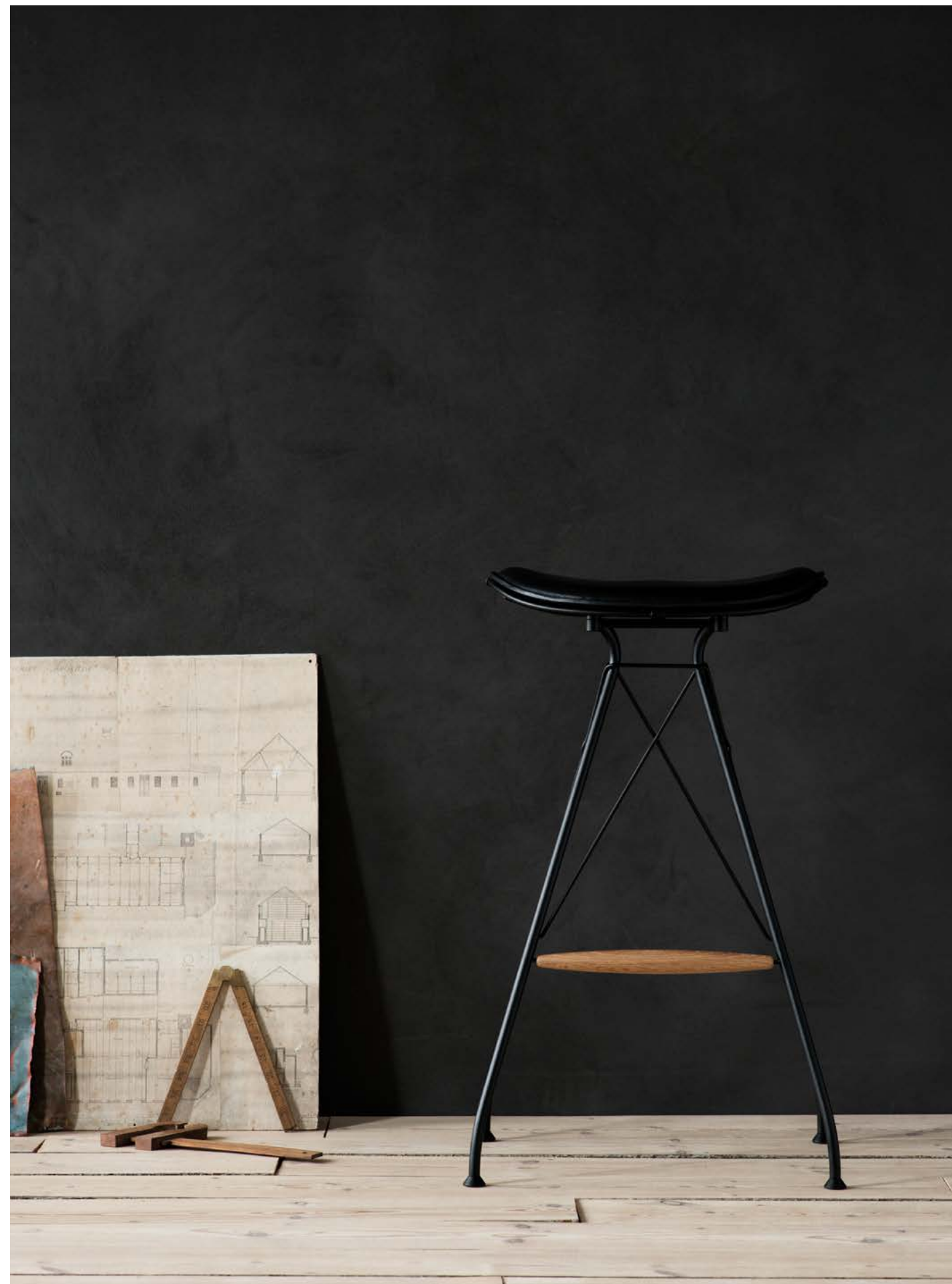





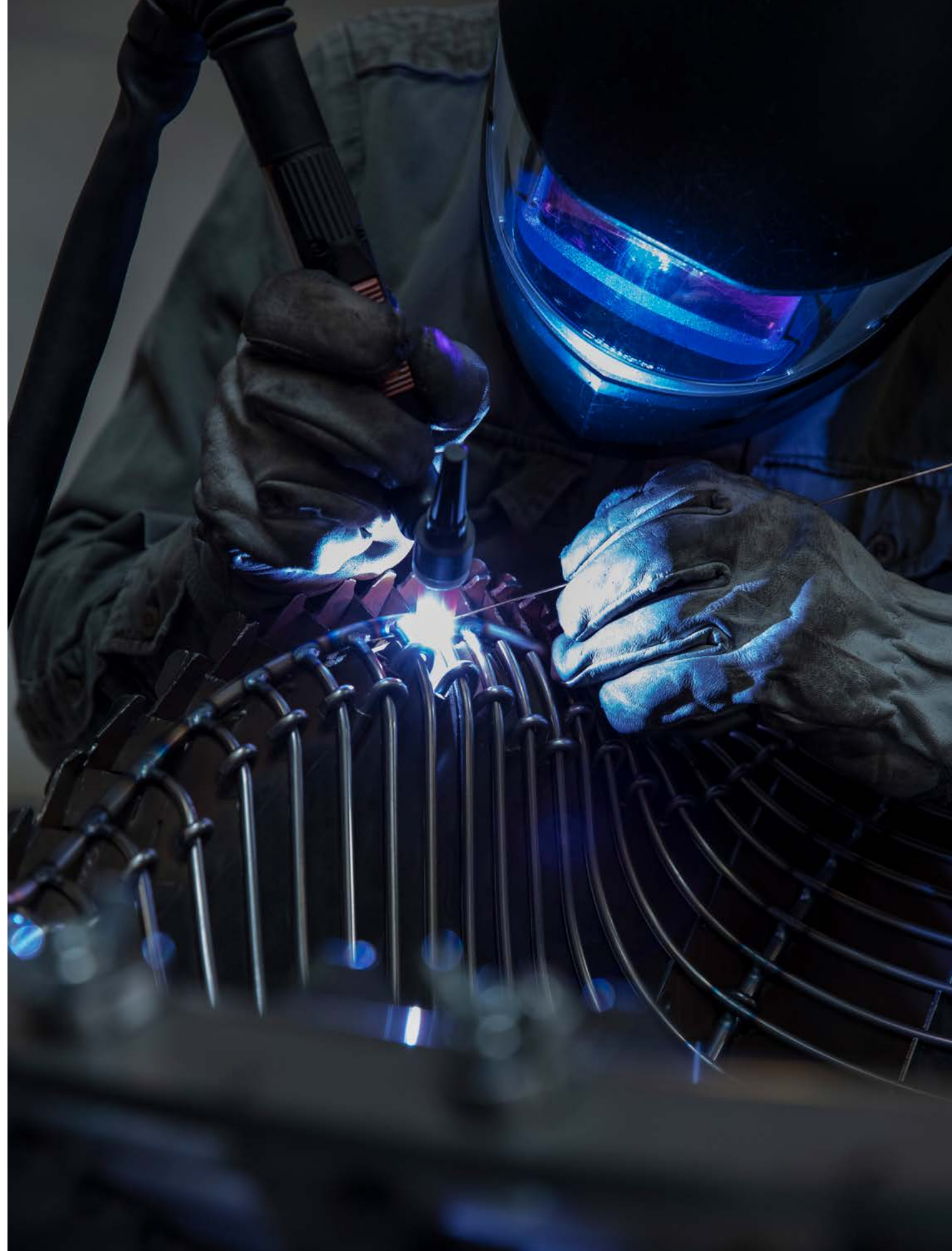



This spread
Welding by hand - it takes 268
welds to make a single Wire
Dining Chair steel seat

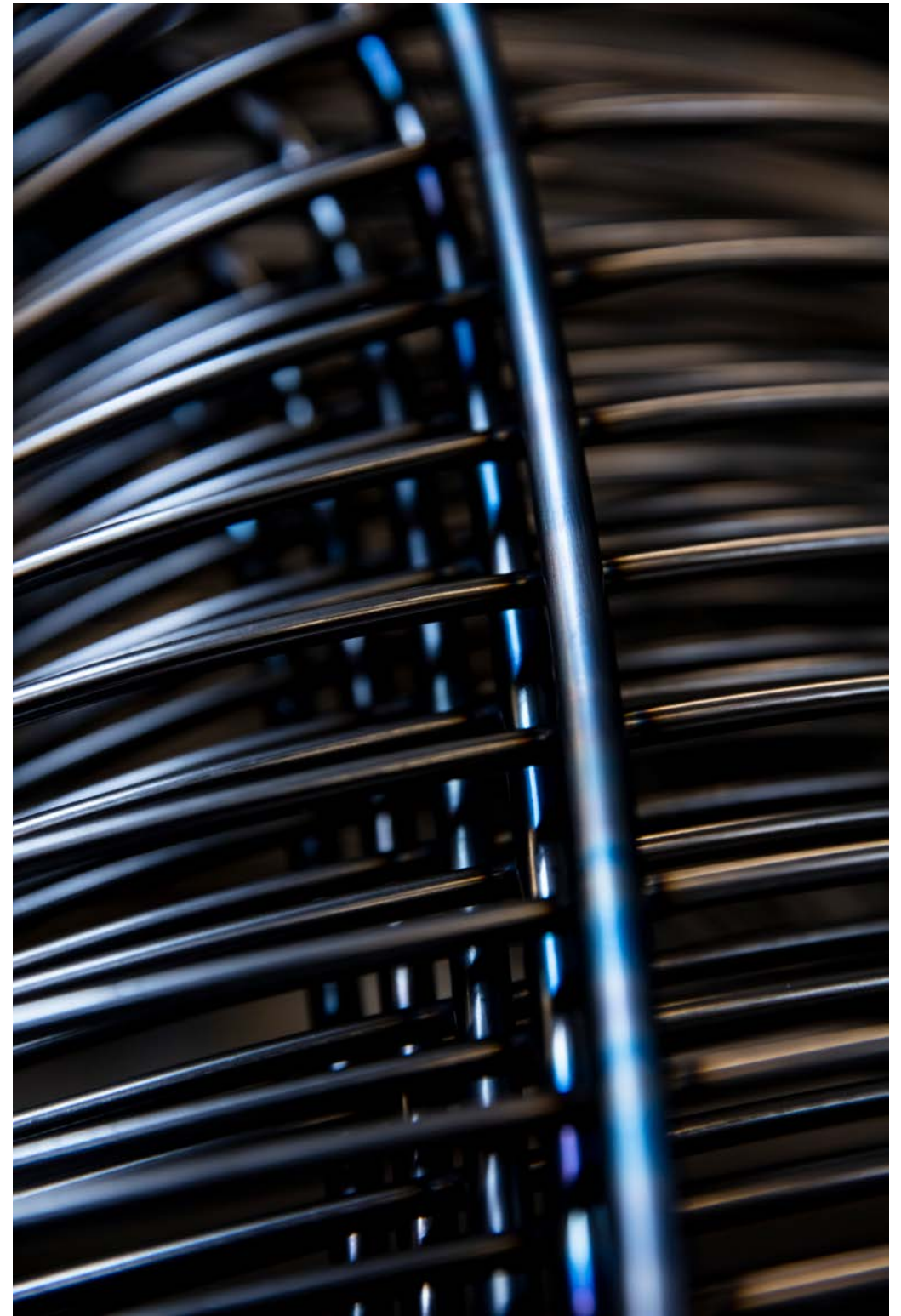



Opposite page
Wire Dining Chair - in
Matstone dark grey leather and
matte black steel



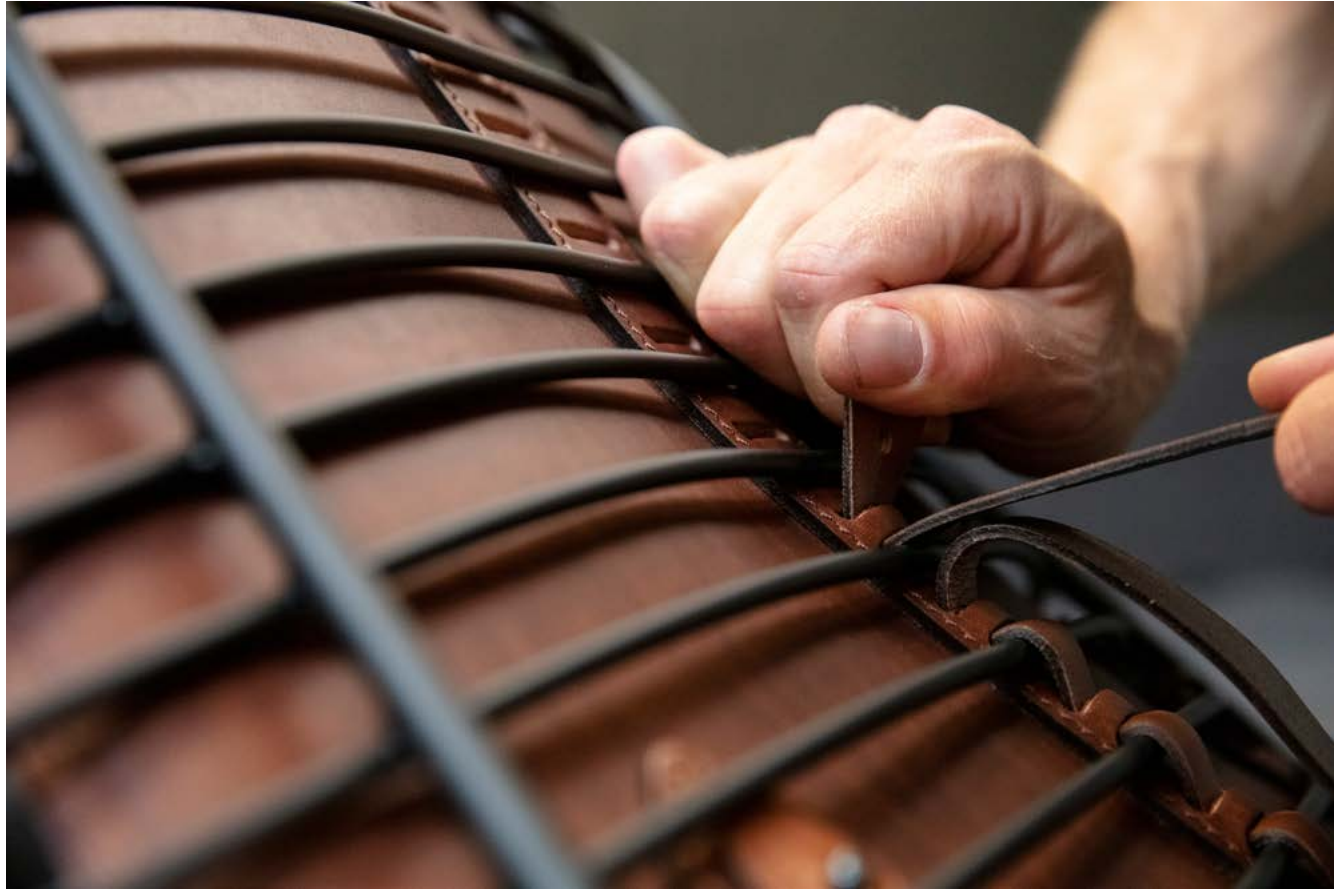

Opposite page
Bottom up Wire Lounge Sofa
seat - in whiskey leather and
satin chrome steel

Next spread
Wire Lounge Sofa and Wire
Lounge Chair - in Yellowstone
dark brown leather and
satin chrome steel









In this project
Wire Dining Chairs - in
Matstone racing green leather
and matte black steel







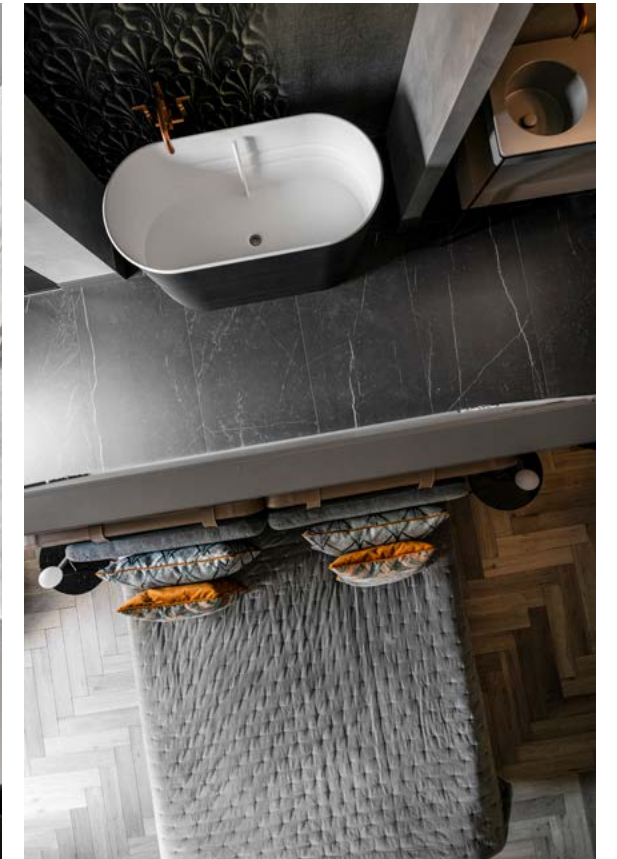

In this project
Wire Lounge Sofa - in Matstone racing green leather and matte black steel
Wire Bar Stools (low) - in Matstone racing green leather, mahogany footrest and matte black steel



In this project
Wire Dining Chairs - in Two Tone
Matstone sand/black leather and
matte black steel









In this project
Circle Dining Chair with
armrest - in smoked oak,
Elegance whiskey leather,
natural leather cord and brass





In this project

Wire Bar Stools (high) - in Yellowstone whiskey leather, oiled oak footrest and satin chrome steel

Wire Dining Chairs - in Yellowstone whiskey leather and satin chrome steel



In this project
Wire Dining Chairs - in Elegance
whiskey leather and satin chrome steel



In this project
Wire Dining Chairs - in Two Tone
Matstone sand/black leather and
matte black steel
Wire Bar Stools (low) - in Two Tone
Matstone sand/black leather, smoked
oak footrest and matte black steel

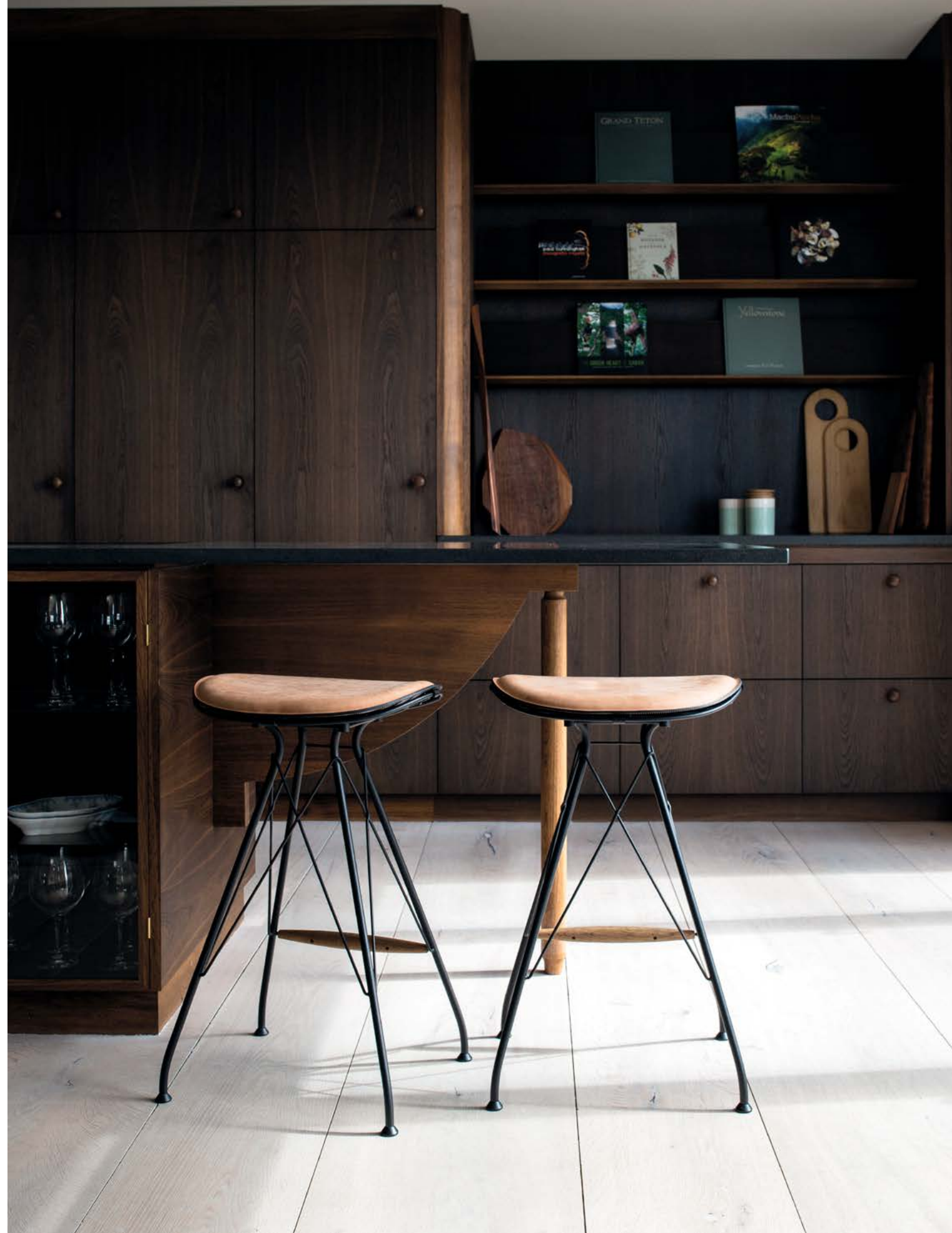





In this project
Wire Dining Chairs - in
Yellowstone whiskey leather
and satin chrome steel

CATSKILL COTTAGE

Woodstock, US

PHOTOGRAPHS BY SØREN ROSE STUDIO

PROJECT BY SØREN ROSE



In this project
Wire Bar Stools (low) - in Elegance
black leather, oiled oak footrest and
matte black steel

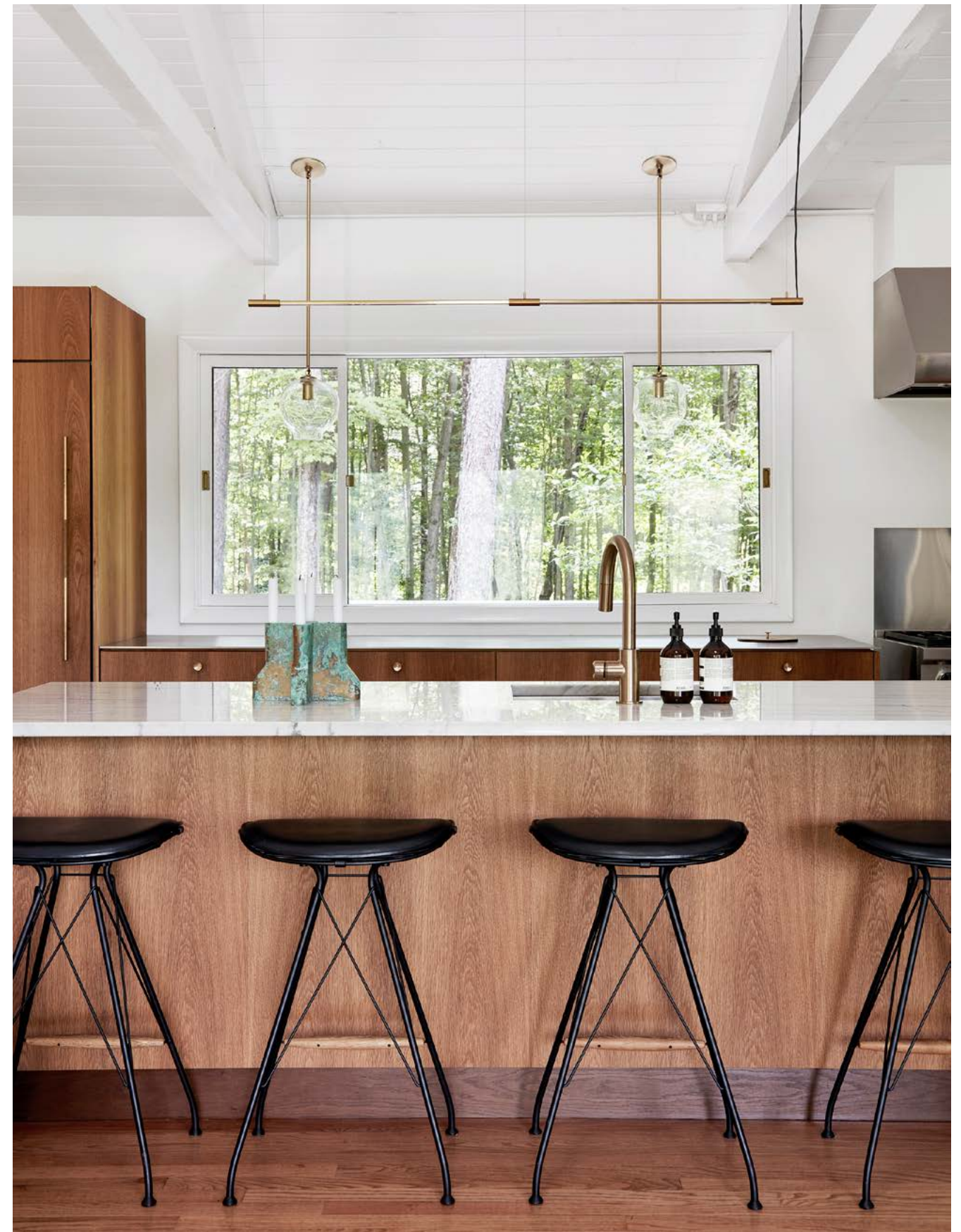



In this project
Wire Bar Stools (high) - in Matstone
racing green leather, oiled oak
footrest and matte black steel
Wire Dining Chairs - in Elegance
whiskey leather and matte black steel





PRIVATE HOME

Ry, Denmark

PHOTOGRAPHS BY JAKOB KIRK VON LOTZBECK



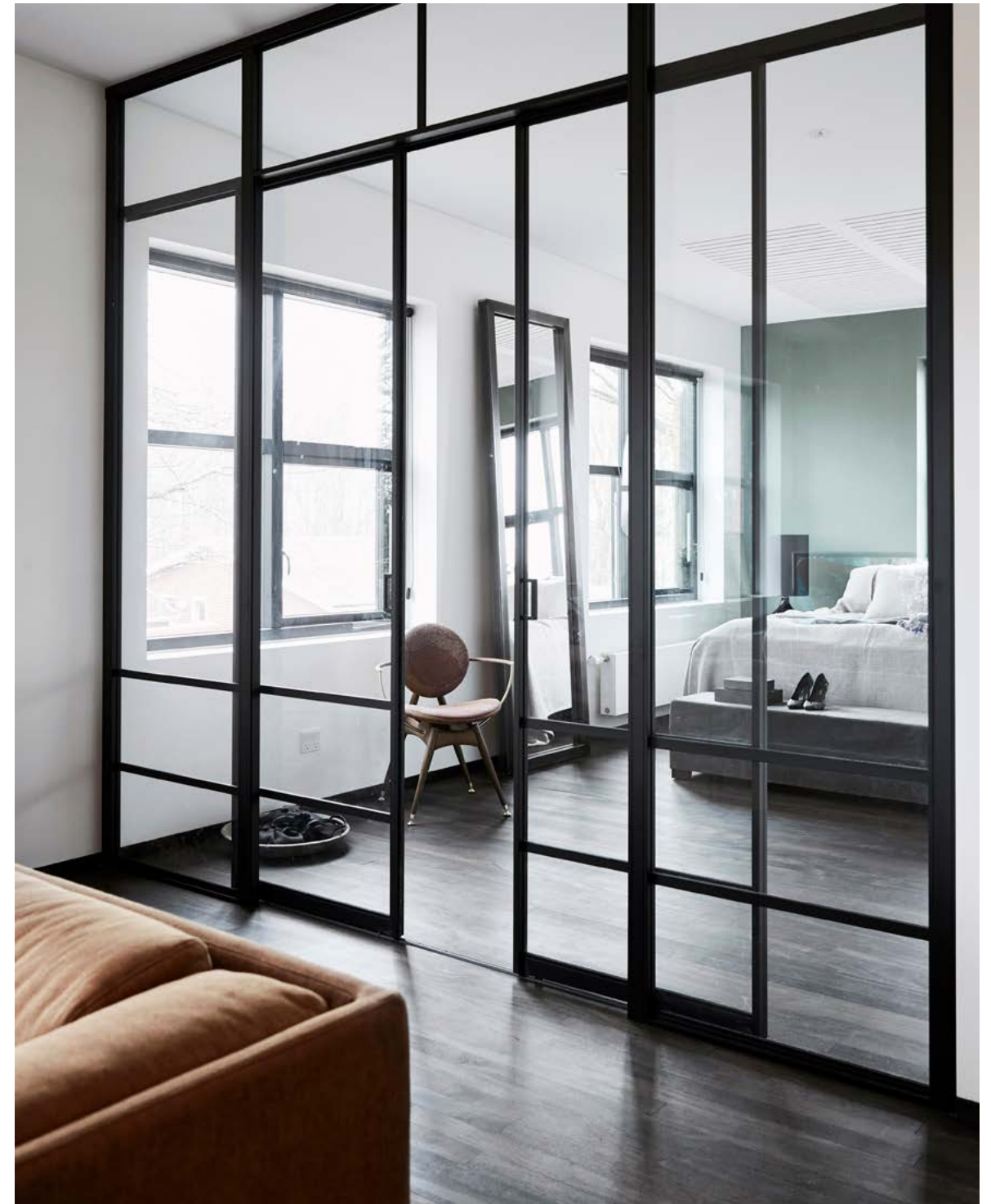

In this project
Wire Bar Stool (low) - in Yellow-
stone whiskey leather, smoked oak
footrest and satin chrome steel
Wire Dining Chairs - in Two Tone
Matstone dark grey/black leather
and matte black steel
Circle Dining Chair - in smoked
oak, Maralinga fabric,
natural leather cord and brass

CIRCLE DINING CHAIR Without Armrest

OD210

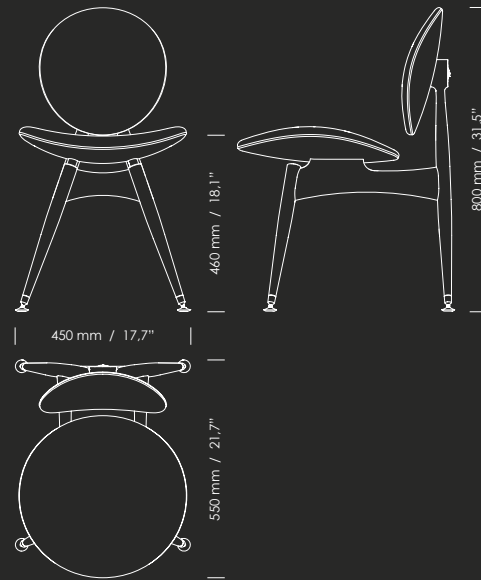

WIRE DINING CHAIR Low

OD11-43

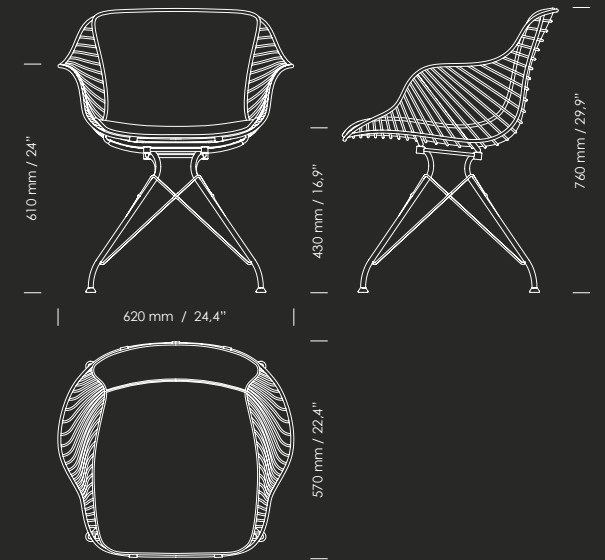

CIRCLE DINING CHAIR With Armrest

OD211

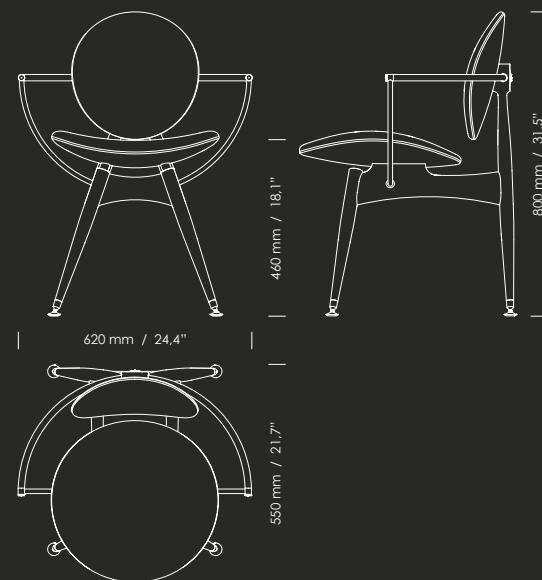

WIRE DINING CHAIR High

OD11-46

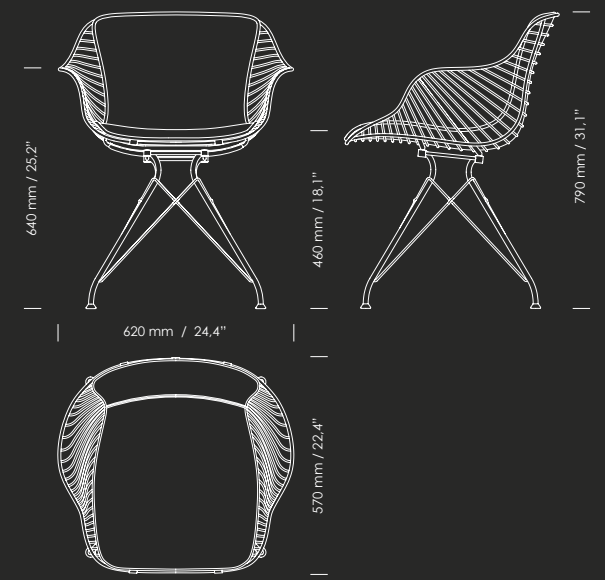

WIRE LOUNGE CHAIR

OD12

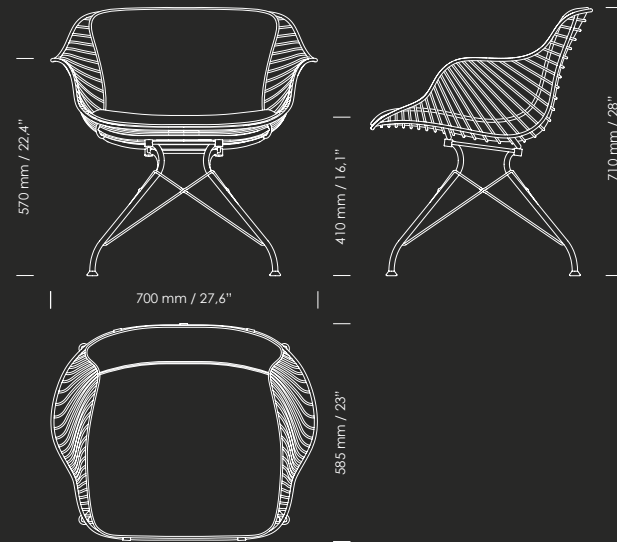

WIRE BAR STOOL Low

OD15-68

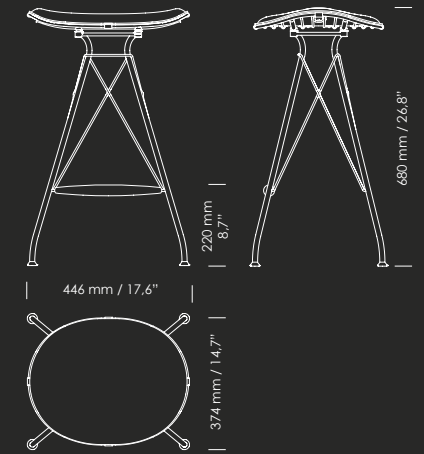

WIRE LOUNGE SOFA

OD13

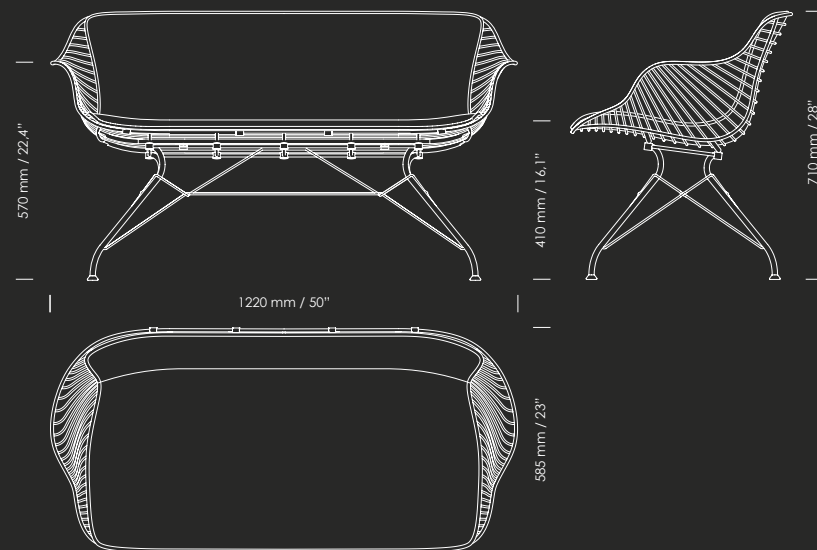

WIRE BAR STOOL High

OD15-75

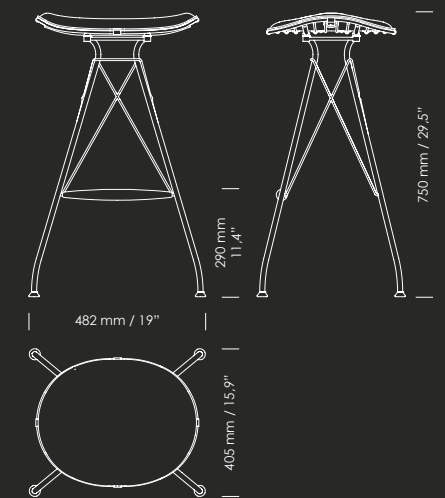

WIRE COFFEE TABLE

OD14

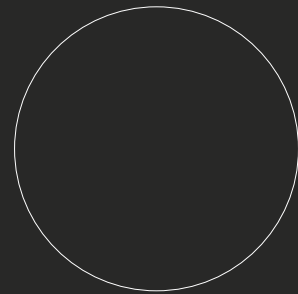
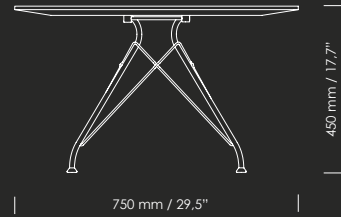

WIRE STOOL

OD16

